

ARTICULATION BOOM LIFT

SPECIFICATIONS

MODELS	AR11JE-2 (AR35JE-2)	
Measurements	Metric	Imperial
Work Height Max.	12.75m	41'10"
Platform Height Max.	10.75m	35'3"
Horizontal Outreach	6.78m	22'3"
Up and Over Height	5.32m	17'5"
Platform Length	1.42m	4'8"
Platform Width	0.76m	2'6"
A Stowed Length	5.77m	18'11"
Length-Transport (jib tucked)	4.46m	14'8"
B Overall Width	1.85m	6'1"
C Stowed Height	2m	6'6"
Height-Transport	2.29m	6'7"
D Wheelbase	1.88m	6'2"
E Ground Clearance	0.19m	7"

PRODUCTIVITY

Max. Platform Occupants	2	
Platform Capacity	270kg	595 lbs
Turntable Rotation	355°	
Drive Speed-Stowed	5km/h	3.1mph
Drive Speed-Raised	0.8km/h	0.5mph
Gradeability	45%	
Max. Wind Speed	12.5m/s	28mph
Turning Radius-Inside	2.6m	8'6"
Turning Radius-Outside	4.7m	15'5"
Max. Working Slope	3°/4.5°	
Tires Type	Foam-filled non-marking	
Tires Models	10-16.5	
Ground Pressure, Tyres	289kPa	41.9psi

POWER

Power Source	80V 125Ah	
--------------	-----------	--

HYDRAULIC SYSTEM

Hydraulic Oil Volume	16L	6.6gal
----------------------	-----	--------

WEIGHT

Machine Weight	5,350kg	15,322 lbs
----------------	---------	------------

STANDARD FEATURES

Auto-leveling platform
Full proportional joystick control
Descent alarm
Flashing beacons
Horn/Hour meter
Over-tilt protection system
Emergency stop button
Intelligent self-diagnosis function
Cylinder bellows
OTA remote upgrade
Dustproof components
AC power to platform
Half-height mesh platform
White noise alarm

OPTIONAL

Wheel chocks x 2 with bracket
Wheel nut indicator

MACHINE SIZE / WORKING RANGE

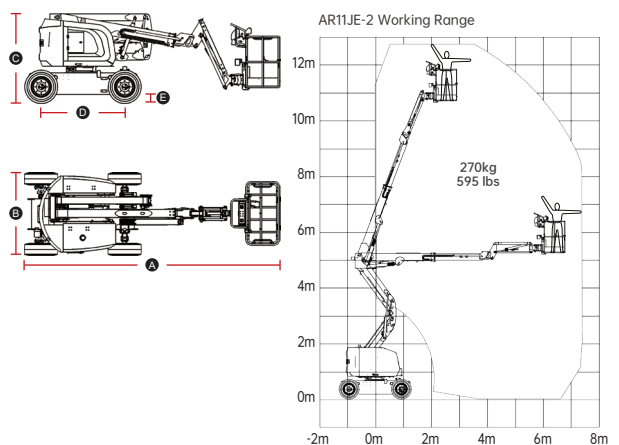

Please contact LGMG or a local dealer for more details.

LGMG reserves the right to change technical data without prior notice. All photos and pictures in this brochure are for promotional purposes only.