



SC0610E-2

CRAWLER SCISSOR LIFT



The 2 Series



LGMG's crawler scissor lift excels in challenging any complex environments, offering outstanding performance on slopes and uneven ground.

- With a compact size and the ability to turn 360 degrees on the spot, the machine is highly maneuverable, allowing for precise operation in narrow space.
- The crawler chassis has a large contact area with ground to provide superior obstacle-surpassing capabilities while maintaining smooth operation and stability.
- The innovative crawler design allows a uniform distribution of total weight to lower ground pressure and prevent damage.

SCISSOR LIFTS

SPECIFICATIONS

MODELS	SC0610E-2	
Measurements	Metric	Imperial
Work Height Max.	8.8m/7.5m (in/out)	28'10"/24'7" (in/out)
A Platform Height-Raised	6.8m/5.5m (in/out)	22'4"/18'1" (in/out)
B Platform Length	1.895m	6'3"
C Platform Width	0.73m	2'5"
D Overall Length	2.052m	6'9"
E Overall Width	0.99m	3'3"
F Overall Height-Guardrails Up	2.192m	7'2"
G Extension Deck	0.9m	2'
Ground Clearance	115mm	4.5"
PRODUCTIVITY		
Max. Platform Occupancy	2(in) / 1(out)	
Platform Capacity	250kg	551 lbs
Platform Capacity-Extension Deck	120kg	265 lbs
Gradeability-Stowed	30%	
Min. Turning Radius	In-situ steering	
Raise/Lower Speed	36s/36s	
POWER		
Power Source	24V((4x6V), 200Ah, AGM)	
HYDRAULIC SYSTEM		
Hydraulic Oil Capacity	5.5L	1.45gal
WEIGHT		
Machine Weight	1,600kg	3,527 lbs

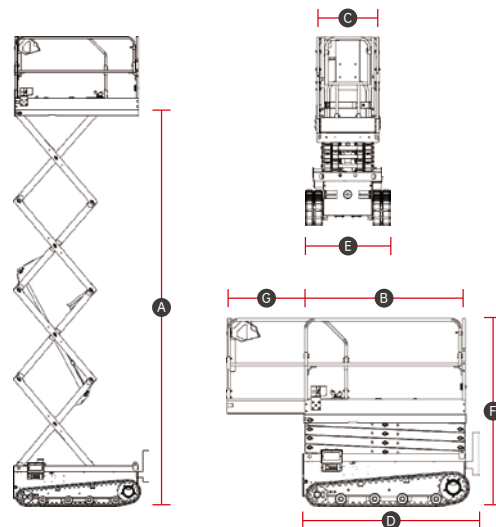

STANDARD FEATURES

- Proportional controls
- Emergency stop device
- Emergency descent
- Self-lock entry gate
- Tilt alarm with lift cut-out
- Overload sensing system
- Descent alarm with flashing beacon
- All motions alarm
- Intelligent diagnostic system
- Foldable ladder
- Non-marking crawlers
- Maintenance-free battery
- AC power to platform

OPTIONS

- Anti-collision protection
- Overload sensing system
- Telematics
- Biodegradable hydraulic oil

Please contact LGMG or a local dealer for more details.

LGMG reserves the right to change technical data without prior notice. All photos and pictures in this brochure are for promotional purposes only.