

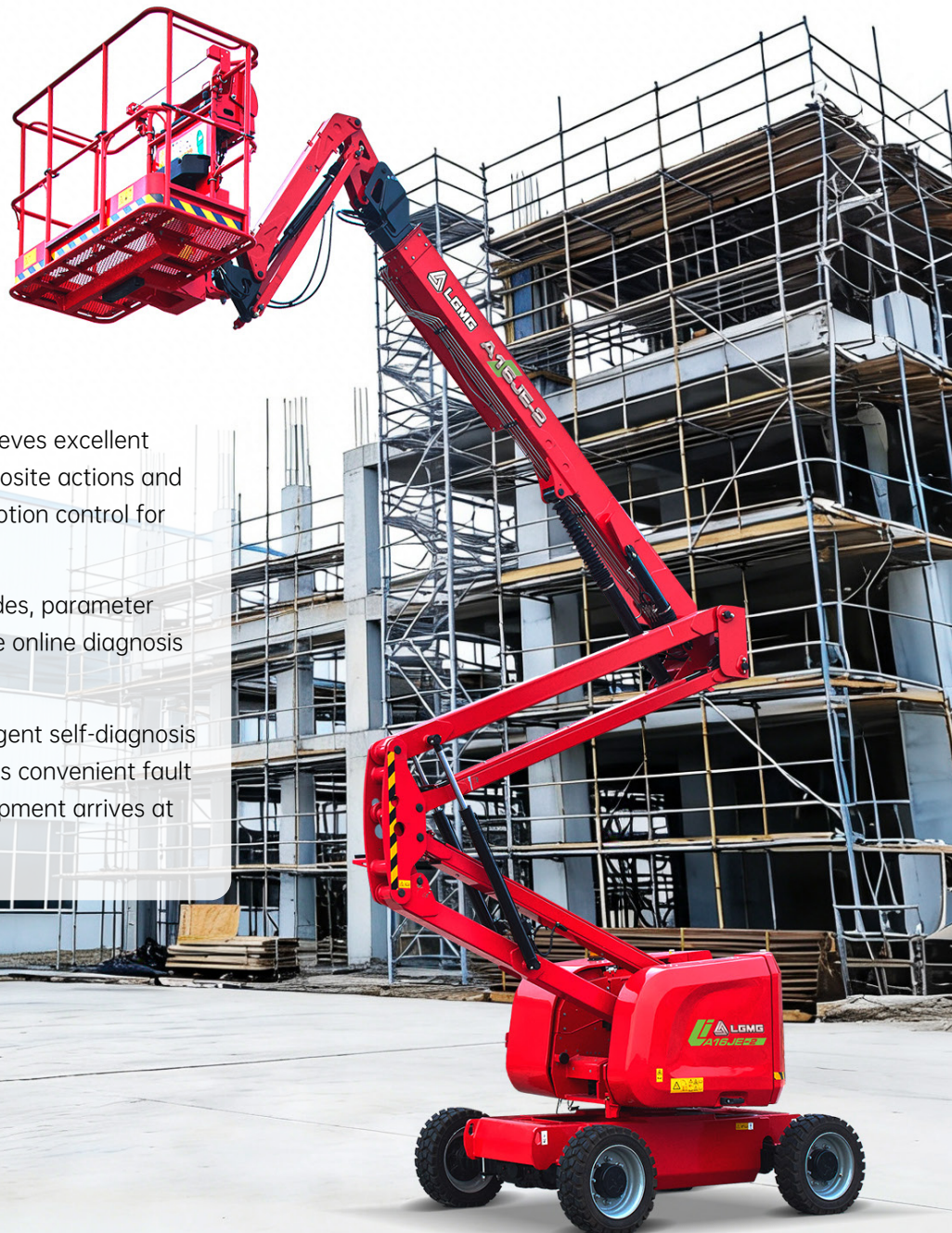

A16JE-2

ARTICULATING BOOM LIFT



- Proportional control achieves excellent synchronization of composite actions and realizes precise micro-motion control for comfortable operations.
- Remote software upgrades, parameter adjustments, and remote online diagnosis through telematics.
- Equipped with the intelligent self-diagnosis function, which facilitates convenient fault detection when the equipment arrives at or departs from the site.

ARTICULATION BOOM LIFT

SPECIFICATIONS

MODELS	A16JE-2	
	Metric	Imperial
Measurements		
Work Height Max.	17.7m	58'1"
Platform Height Max.	15.7m	51'6"
Horizontal Outreach	9.49m	31'2"
Up and Over Height	7.26m	23'10"
Platform Length	1.83m	6'
Platform Width	0.76m	2'6"
A Stowed Length	7.407m	24'4"
Transport Length (jib tucked)	5.99m	19'8"
B Overall Width	1.87m	6'2"
C Stowed Height	1.96m	6'5"
Transport Height	2.42m	7'11"
D Wheelbase	2.03m	6'8"
E Ground Clearance	0.18m	7.1"

PRODUCTIVITY		
Platform Capacity (unrestricted)	230kg	507 lbs
Platform Capacity (restricted)	350kg	772 lbs
Max. Platform Occupancy	2(unrestricted)/3(restricted)	
Turntable Rotation	355°	355°
Drive Speed-Stowed	5km/h	3.1mph
Drive Speed-Raised	0.8km/h	0.5mph
Gradeability	30%	30%
Max. Wind Speed	12.5m/s	28mph
Turning Radius-Inside	2.22m	7'3"
Turning Radius-Outside	4.6m	15'1"
Max. Slope	4.5°/4.5°	4.5°/4.5°
Tire Type	Solid	
Tire Models	250-15	
Ground Pressure, Tyres	1160 kPa	168.2 psi

POWER		
Power Source	80V 125Ah	

HYDRAULIC SYSTEM		
Hydraulic Oil Volume	30L	7.9gal

WEIGHT		
Machine Weight	7,650kg	16,865 lbs

STANDARD FEATURES

- Auto-leveling platform
- Hydraulic rotating platform 180°
- Full proportional joystick control
- Descent alarm
- Flashing beacons
- Horn/Hour meter
- Over-tilt protection system
- Emergency stop button
- Intelligent self-diagnosis function
- Cylinder bellows
- OTA remote upgrade
- Dustproof components
- Over-head anti-collision protection
- Platform tool box
- AC power to platform

OPTIONAL

- Platform work light
- Half-height mesh platform
- Platform auxiliary guardrail
- Platform pipe rack

MACHINE SIZE

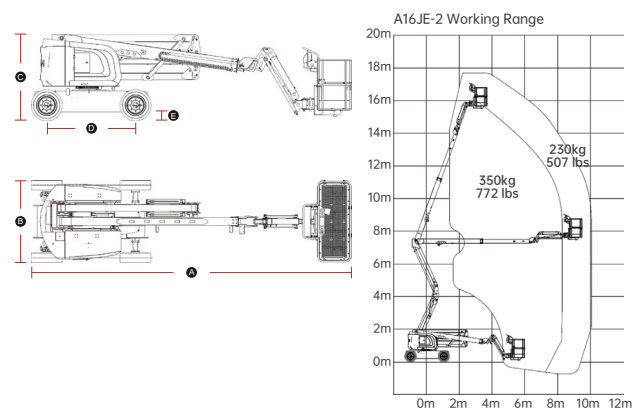

Please contact LGMG or a local dealer for more details.

LGMG reserves the right to change technical data without prior notice. All photos and pictures in this brochure are for promotional purposes only.